

OIOLI



OIOOLI

BATHROOM 2023



BRAND STORY



Oioli began 60 years ago on Orta lake's shore; the piedmontese land of high quality taps and fittings, when the young Eusebio Oioli started producing and commercialising his products.

Simple taps, characterised by essential design and produced with great care. As all stories of those years, this historical company started with a life of privations, hard and tough work. A tradition that has not come to an end, as today, we can see the third generation, Oioli; a factory in continuous development.

The production is organised in a catalogue of more than 35 complete series, in which have been created after rigorous research of style and functionality. Thanks to the new settlement in Gozzano and to an efficient commercial network, the factory is growing on all national and international markets. offering an excellent product branded "Made In italy" and studied after intelligent and professional work.

Quality and italian genius/innovation are appreciated and recognized all over the world; this encourages us to keep on producing and feeling proud of our work, which is an old tradition.

FINISHINGS

GALVANIC PLATING PROCESS



PHYSICAL VAPOR DEPOSITION



POWDER COATING

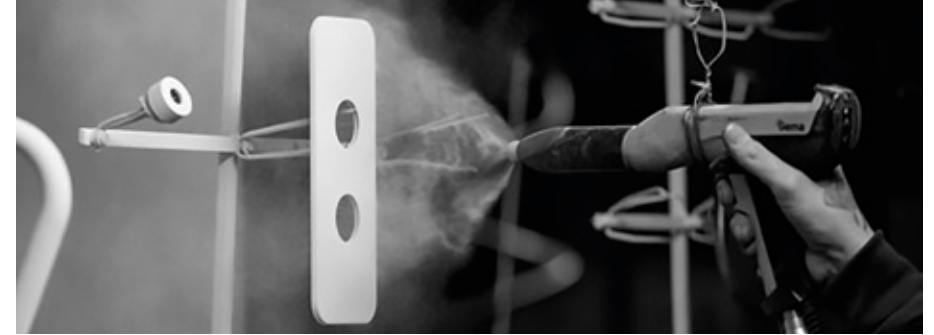

OIOLI
LAB RESEARCH & DEVELOPMENT



OEM Project

- Customer relationship
- Customised Design Project
- 3D Prototyping
- Availability +25 colours
- Customised Logo & Packaging
- Water flow and Materials Testing
- Production Flexibility

DESIGNER

Giacomo Zucchi

Giacomo Zucchi is a young Italian designer (Omegna 1977) who has received prestigious awards all over the world. He grew up in the area called "Cusio", in the north-west, famous industrial cradle of many important Italian factories in the household and bathroom product category. In 2001, he took his Degree in Industrial Design at the Politecnico di Torino and he started his professional career drawing collections for the historic Italian company Lagostina (cookware and tableware) with whom he received the prizes Reddot Design Award (Germany 2009), Good Design Award (Chicago Athenaeum Museum 2009) and Good Design Award (JPD, Japan 2009).

In 2011, he received the "Cavalierato giovanile", an award sponsored by the Presidency of

the Italian Republic, as recognition for having distinguished himself at international level and as a representative of Italian talent. The same year he moved to France joining the French multinational SEB (Tefal, WMF, Rowenta, Moulinex), where he collaborated with an international team of designers and where, working in close contact with the International Product Strategic Management, he deepened the knowledge of Strategic Design, Project Management and Product Innovation. During the French mission, he received the "Etoile du Design" (Paris 2014) thanks to a project of innovative ceramic knives and in Munich, he receives the "IF Design Award" (2017) with the "Experience by Tefal" kitchen collection.



A handwritten signature in black ink, appearing to read 'G. Zucchi', located in the bottom right corner of the page.

INDEX



GLAM



ZEN



KREÓ



NOLI



PURA



5TH AVENUE

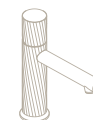

NAVONA

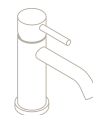

LIFE
Stainless Steel 316

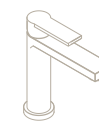

SPRITZ



VIDA

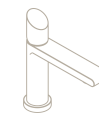

JAZZ

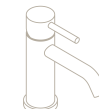

MICRO

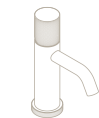

MICRO₈₀

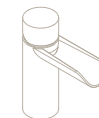

MIRAME



OPÉRA



KING

GLAM
Design by Giacomo Zucchi



"I focused on the idea of simplicity and on the use of pure shape to create an empathic and unique object, capable to generate a tactile pleasure and a sense of harmony by it's use."

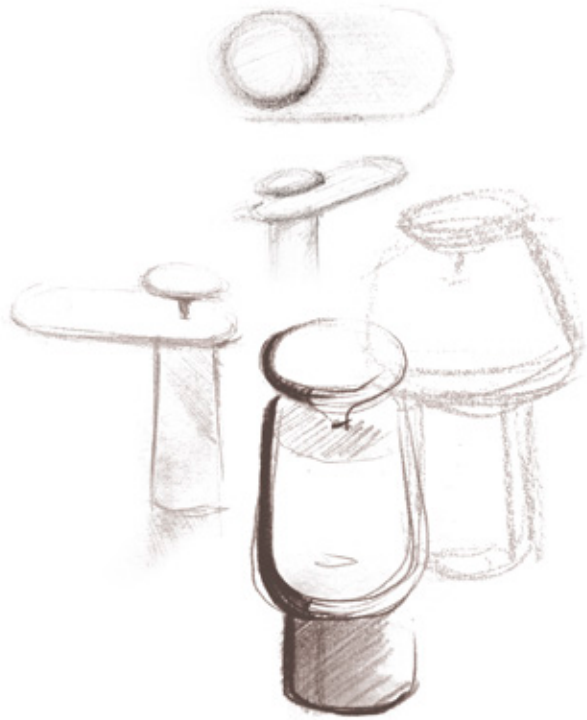



GLAM



ZEN

Design by Giacomo Zucchi



ZEN

2019 PLATINUM WINNER
**EUROPEAN
PRODUCT
DESIGN
AWARD**



ZEN

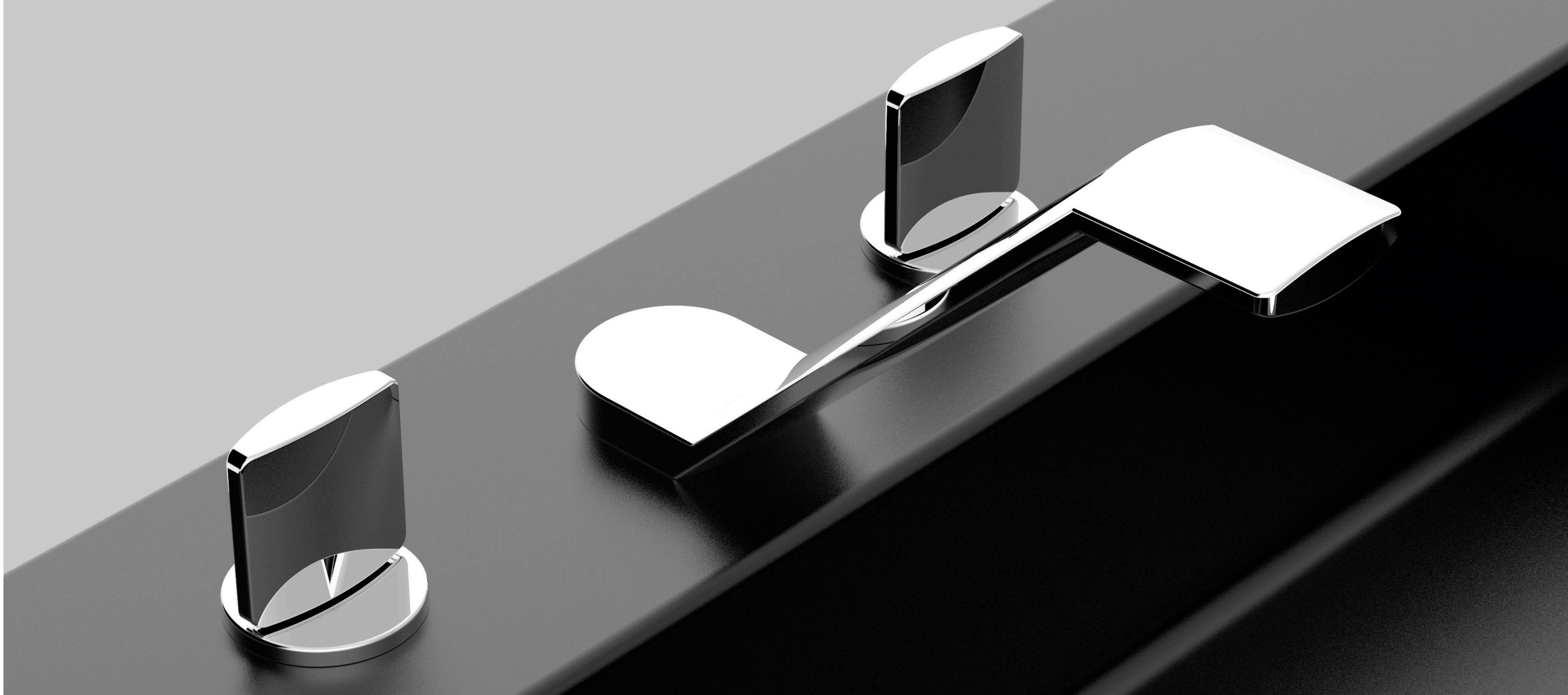



ZEN



KREŃ



KREÓ



KREÓ



KREÓ



NOLI



NOLI



NOLI

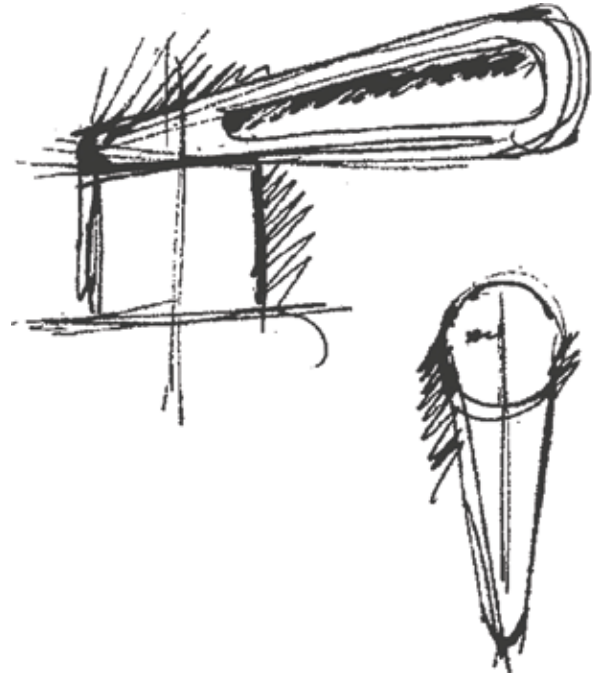

NOLI



NOLI



PURA



PURA



PURA



5th AVENUE



5th AVENUE



FLORENCE HANDLE



5th AVENUE
HANDLES

CLASSIC



WEST



SOHO



GEOM





5th AVENUE



VEGAS HANDLE





TUBE HANDLE





NAVONA



NAVONA



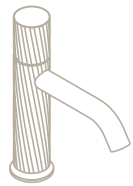

LIFE

Stainless Steel 316



LIFE



LIFE





LIFE

Stainless Steel 316

LIFE z
Stainless Steel 316



SPRITZ



SPRITZ



VIDA



VIDA

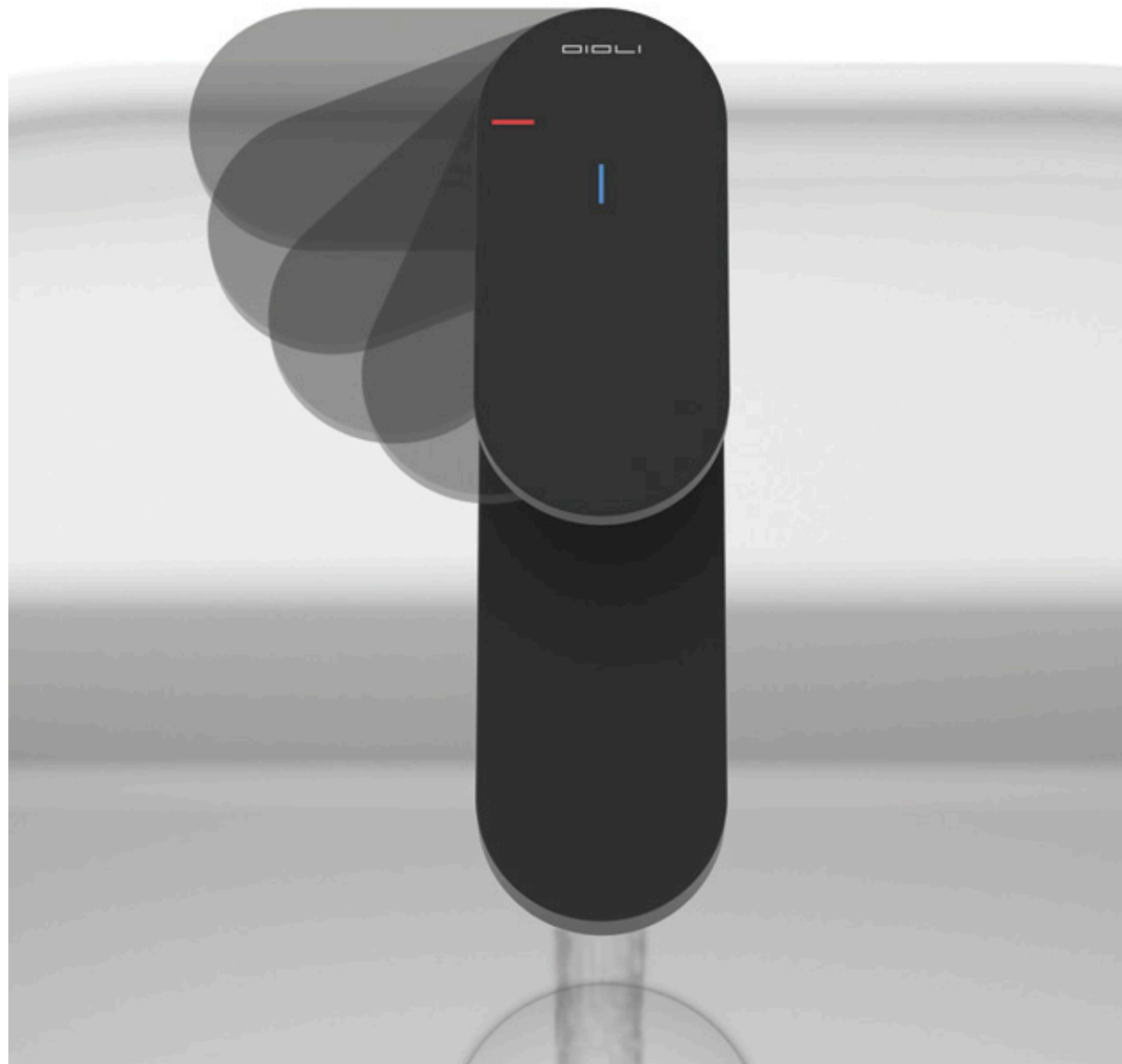

JAZZ



JAZZ

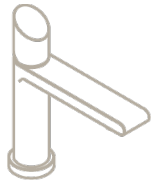

JAZZ



MICRO



MICRO



MICRO



MICRO



MICRO

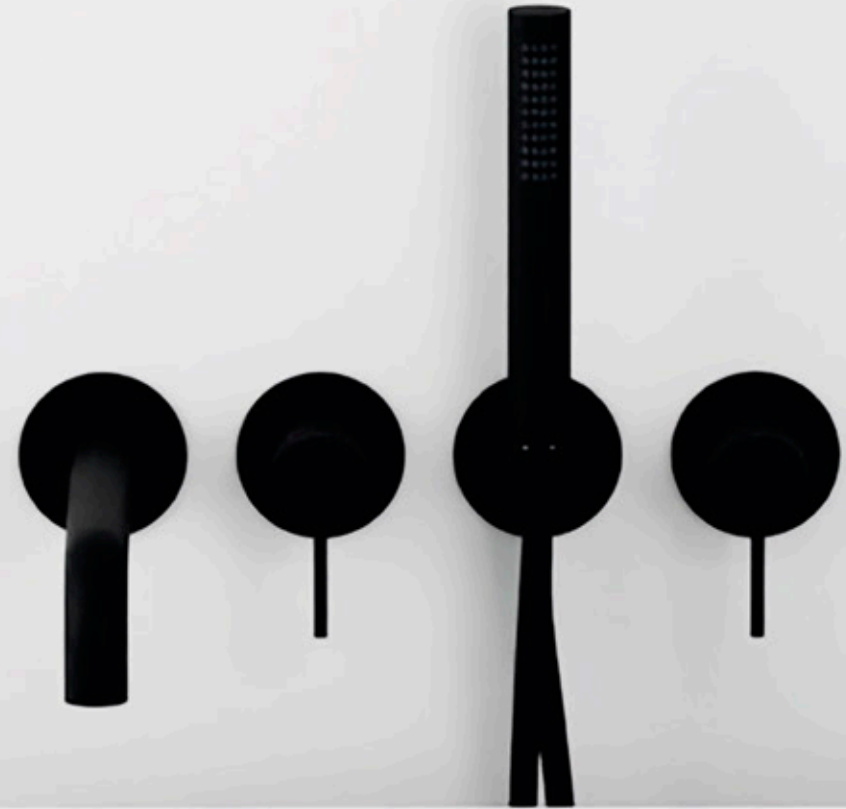

MICRO WOOD



MICRO WOOD



MICRO₈₀



MICRO80



MIRAME



MIRAME



OPÉRA



OPÉRA

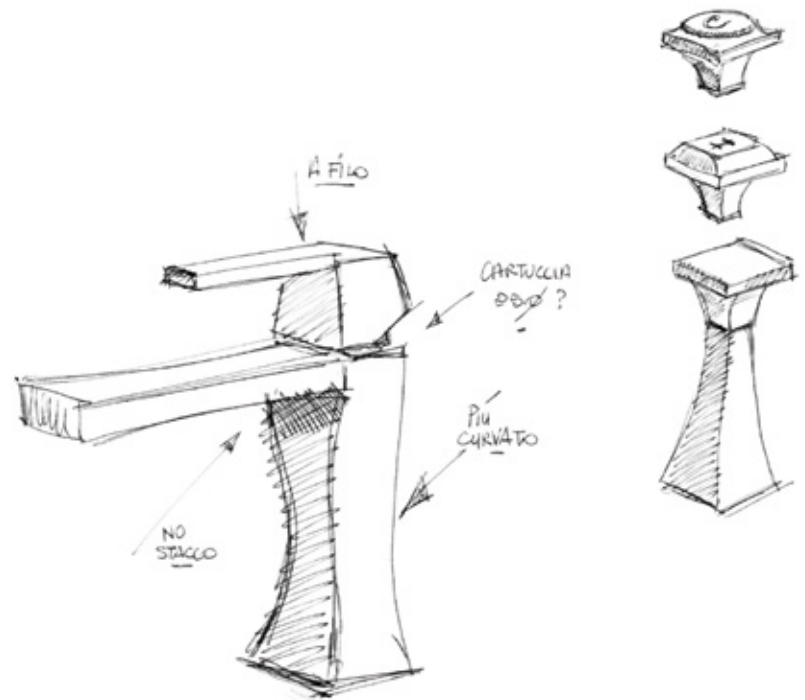



OPÉRA ART



KING



KING

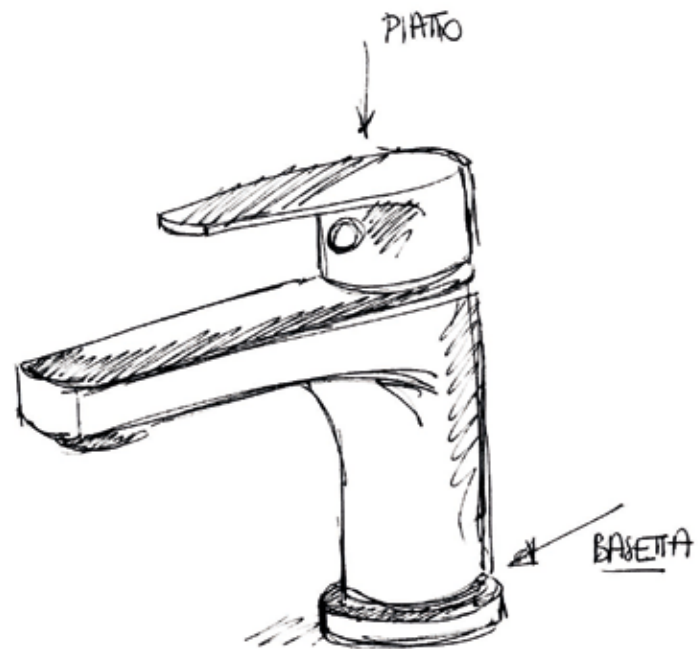

KING



edizione 00/02/2023

OIOLI RUBINETTERIE SRL

Via Pul Stretta 10/12
28024 GOZZANO (NO) - ITALY

www.oioli.com

sales@oioli.com
export@oioli.com

